

## Description

The CPN-IMU-G5A5 is a small, lightweight strap-down Inertial Measurement Unit based on Fiber Optic Gyro (FOG) technology. The CPN-IMU-G5A5 is a high performance IMU, has digital outputs of linear acceleration and angular rates, short data latency for flight control applications. The CPN-IMU-G5A5 is designed for a wide range of applications requiring high reliability and long life.

## Features

- Medium accuracy, small package
- High angular rate capability, 1000 degrees/second
- Solid state, high reliability, long life
- Rugged, high vibration version available

## Applications

- Guided weapons
- Unmanned Air vehicles & Target Drones
- Optronics system stabilization and targeting
- Smart munitions



## Technical index

	Parameter	Unit	Value
<b>1 Performance</b>			
<b>1.1 Gyro channels</b>			
1.1.1	Range	° /s	±1000
1.1.2	Bias stability (1σ)	° /h	≤10
1.1.3	Bias repeatability (1σ)	° /h	≤10
1.1.4	Noise, angle random walk	° /√h	≤0.5
1.1.5	Scale factor Non Linearity	ppm	≤500
1.1.6	Scale factor repeatability (1σ)	ppm	≤150
<b>1.2 Accelerometer channels</b>			
1.2.1	Acceleration Range	g	±50
1.2.2	Bias stability (1σ)	mg	≤5
1.2.3	Bias repeatability (1σ)	mg	≤5
1.2.4	Scale factor repeatability (1σ)	ppm	≤300
1.2.5	Noise	mg/√Hz	2
<b>1.3 IMU</b>			
1.3.1	MTBF	hours	10,000
<b>2 Environment</b>			
2.1	Operating Temperature	°C	-40~+65
2.2	Storage Temperature	°C	-45~+70
2.3	Vibration	Hz,g2/Hz	20...2000,0.04
2.4	Shock	g,ms	80,8
<b>3 Electrical</b>			
3.1	Input Voltage	Vdc	±5
3.2	Power Consumption	W	<15
3.3	Digital Output Format		RS-422

3.4	Output signals	Angular rates and accelerations	
<b>4 Physics</b>			
4.1	Dimensions(sensor)	mm	<94 D * 100H
4.2	Weight	Kg	1 ± 0.05

## Configuration Drawings (all dimensions in mm)

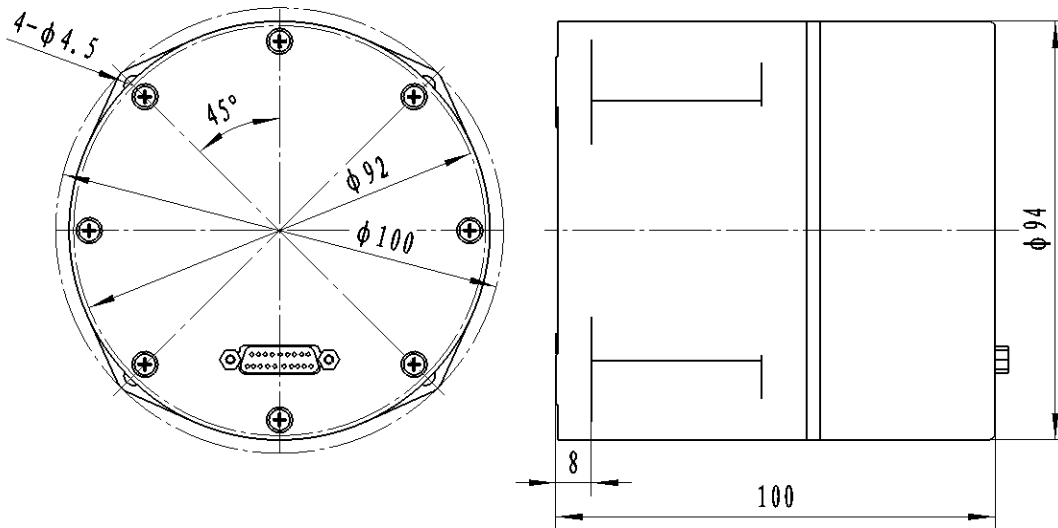

## Interface description

Connector: J30J-21ZKP

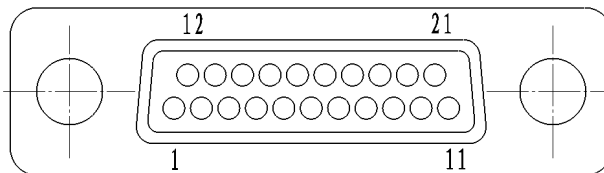

PIN	Signal	PIN	Signal
1	+5V	12	NC
2	+5V	13	NC
3	-5V	14	NC
4	-5V	15	NC
5	GND	16	Used
6	GND	17	Used
7	GND	18	Used
8	RS422-T+	19	Used
9	RS422-T-	20	NC
10	RS422-R+	21	NC
11	RS422-R-		